

MATERIAL CUT LIST	Material	Unit/Length	Quantity
Metal Screw	#12 Drivall	0	514
Metal Screw	#10 Drivall	0	100
Connector (P5)	PL18x12x0.057	0	10
Clip Angle 1	L70	0	10
Simpson	S/H3	0	10
B1	362S162-33(33)	10'-4"	10
T1	362S162-33(33)	13'-4 9/16"	10
Web #1	250S162-33(33)	2'-8 7/8"	10
Web #2	250S162-33(33)	5'-4 1/16"	10
Web #3	250S162-33(33)	5'-2 9/16"	10
Web Stiffener (ws)	250T125-33(33)	3 1/2"	10

GENERAL NOTES

- Number of fasteners noted in chart installed on each end of Web
- When connecting plates to chord or web members, fasteners must pass through the plate and member. If a joint connection has fasteners passing through the web, connector plate and chord, the fastener may be counted as part of the required number of fasteners for that joint.
- Minimum connector spacing (center to center or free edge) = 3/4"
- Truss connector type - #12 Drivall (Grabber)

Number of Trusses = 10 each
 Chord Cut Type = Mitre Cut
 Truss Spacing = 2'-0"
 Number of Plys = 1
 Weight per Truss = 35.3 lbs (per ply)

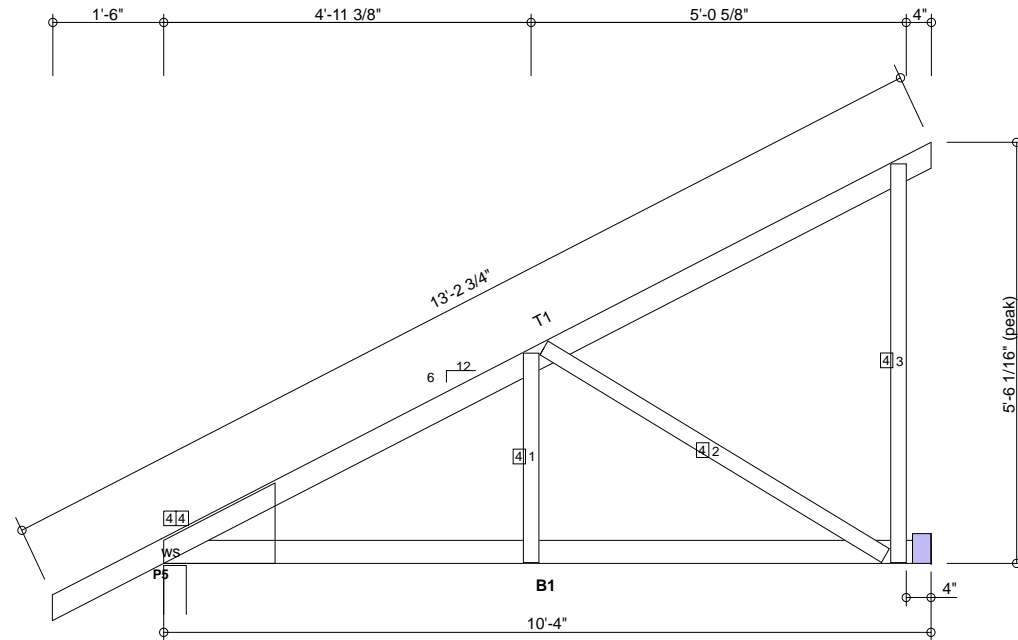
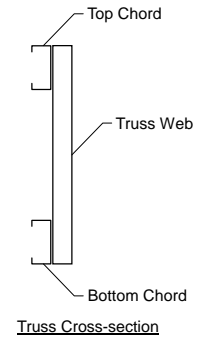

2 denotes number of fasteners @ each end of member (web or chord)
 4 4 denotes number of chord-plate fasteners

Scale: 3/8" = 1'-0"



Rusk Component and Design

11357 Billings Ave
 Lafayette, CO 80026
 (303) 828-5747

Roof Trusses

Lafayette, Co

Truss D&E, V25.011
 Date: 04-26-2015
 Time: 10:44
 Designer: BJR
 File: M-4-10
 Job Number: RoofTruss

This document contains information proprietary to Rusk Component and Design and may not be used or reproduced without prior written consent. Contents subject to change without notice.

M-4-10

Fabrication Drawing